

INSTALLATION GUIDELINE FOR TRYMER® INSULATION ITW INSULATION SYSTEMS

TRYMER RIGID POLYISOCYANURATE INSULATION IN HOT APPLICATIONS (80°F to 300°F)

1 SCOPE

- 1.1 This guideline covers the installation of TRYMER® Rigid Polyisocyanurate Insulation in above ambient and hot piping systems. If the system undergoes cycling such that the service temperature is ever below ambient, the appropriate service temperature guideline should be consulted. Guidelines are provided for both indoor and outdoor applications.
- 1.2 This guideline includes, but is not limited to, installation guidelines for the hot gas portion of refrigeration piping systems.
- 1.3 Product data sheets and other ITW literature are referenced throughout this guideline. Consult your ITW Pipe Insulation Engineering Manual or visit www.itwinsulation.com for the latest version of these documents.
- 1.4 The information contained in this guideline and referenced ITW documents are current as of May 2017. This guideline is subject to revision without notice. Contact ITW Insulation Systems Customer Information Group at 1-800-231-1024 or your local ITW Representative for the most recent version of this guideline or other ITW referenced literature.
- 1.5 Due to the variations in service conditions and use, this guideline may not be pertinent for every application. A design or specifying engineer can create specifications tailored to particular applications or owner's needs. Such a design or specification engineering service may be more familiar with local conditions, budgets, environment, and desired service life of the system allowing them to generate a precise specification.
- 1.6 It is the intent of this document to provide guidelines for the installation of TRYMER Insulation manufactured by ITW Insulation Systems. This guideline may not be suitable and shall not be used for the purpose of installing other insulation manufacturer's products. While supplemental insulation products may be referenced in this guideline, ITW recommends consulting the manufacturers of such products for proper installation and handling.
- 1.7 **This guideline is offered as a guide for the purpose described herein. No warranty of procedures, either expressed or implied is intended. All other express or implied warranties of merchantability or fitness for a particular purpose are disclaimed.**

2 GENERAL

- 2.1 All piping shall be free of foreign substances and free of surface moisture or frost prior to the application of insulation.
- 2.2 All insulation material shall be delivered to the project site in original, unbroken factory packaging labeled with product designation and thickness. The shipping package should not be air-tight. Shipment of materials from the manufacturer to the installation location shall be in weather-tight transportation. Insulation materials delivered to the job-site shall be stored so as to protect the materials from moisture and weather during storage and installation. Insulation material shall be protected from sunlight to avoid long exposure to UV light from the sun.
- 2.3 All testing of piping systems shall be completed prior to the installation of the insulation system.
- 2.4 Refer to the insulation thickness charts in Appendix C to determine recommended insulation thickness based on desired design criteria for ambient and service conditions.

3 MATERIALS OF CONSTRUCTION

3.1 INSULATION MATERIALS FOR ABOVE AMBIENT AND HOT SERVICES

- 3.1.1 Insulation shall be TRYMER 1800 or 2000 XP Rigid Polyisocyanurate Insulation manufactured by ITW Insulation Systems (Insulation).

- 3.1.2 For applications requiring a flame spread/smoke developed index of 25/50 per ASTM E84, or Class I according to NFPA 255, insulation shall be TRYMER Supercel Phenolic. For all other applications, insulation shall be TRYMER 1800 or TRYMER 2000 XP.
- 3.1.3 Insulation shall have a maximum thermal conductivity of 0.19 BTU-in/hr-ft²°F (0.027 W/m°-C) at 75°F.

3.2 FABRICATION OF INSULATION

- 3.2.1 Insulation shall be fabricated in required shapes from bun stock in accordance with ASTM C-450 “Standard Practice for Prefabrication and Field Fabrication of Thermal Insulating Fitting Covers for NPS Piping, Vessel Lagging, and Dished Head Segments and C-585 “Standard Practice for Inner and Outer Diameters of Rigid Thermal Insulation for Nominal Sizes of Pipe and Tubing” (NPS System). Insulation shall be factory fabricated from bun stock.
- 3.2.2 Fittings, such as valves, valve stations, flanges, 90° and 45° elbows, and tees shall be two-piece fly-cut or routed as the preferred fabrication method. For diameters, too large for fly-cutting or routing, the pieces shall be fabricated in two halves with each half made up of mitered sections. Both methods shall be in accordance with ASTM C-450 and ASTM C-585. Larger outer diameter valves and flanges may be slightly oversized.
- 3.2.3 Insulation for electrical tracing systems shall be oversized by 1/2" inside insulation radius on bottom half shells only. Outside insulation diameters shall remain the same on bottom and top sections. The 1/2" annular space on the bottom half section will allow spacing for the electrical tracing system. See figure 4. Do not oversize the bottom half shell of insulation at pipe hangers and supports. When over-sizing the bottom half shell, the insulation thickness of the bottom half shell shall be that specified as the “design thickness”. The insulation thickness of the upper half shell shall be 1/2” larger than the “design thickness” so that the outer diameters of the top and bottom half shells match.
- 3.2.4 Store the bun stock at normal shop (indoor) conditions for at least 24 hours before fabrication. This will allow the TRYMER bun stock to equilibrate to the shop conditions. For best fabrication quality, it is recommended that TRYMER buns be fabricated into pipe shells in conveyor direction (36” direction) to maximize flatness. The fabricated pipe shells may be aged for 24 hours before vapor retarder attachment. Similarly, after fabrication of the fittings/elbows/tees, allow the cut pieces to age for 24 hours before factory application of the vapor retarder to the fabricated pieces. After application of vapor retarder, fabricated pipe shells shall not be stored for more than one month either in the warehouse or at a job site.

3.3 ADHESIVES, JOINT SEALERS and MASTICS

- 3.3.1 Solvent based adhesives may be used in contact with TRYMER Insulation. Weather barrier type mastic products may be used in hot and dual temperature services. Weather barrier product must be weatherproof, breathing type for both indoor and outdoor use.
- 3.3.2 Joint sealers for sealing all PVC slip joints shall be weatherproof type, moisture and water resistant, non-hardening, flexible with a service temperature range of 0°F to +300°F.

3.4 PROTECTIVE JACKETING MATERIALS

3.4.1 Indoor Jacketing

- 3.4.1.1 Jacketing shall be PVC material where frequent wash-downs are expected. Consult jacketing manufacturer for recommended thickness. Typical thickness is 0.010 to 0.030”. Jacketing shall be tough, and capable of enduring frequent wash-downs with hot water or cleaning agents. All joints of PVC jacket shall be solvent welded. Refer to section 3.3.2 regarding PVC slip joints.
- 3.4.1.2 Supply preformed PVC covers for all fittings, tees, elbows, valves, caps, etc. at same thickness as PVC on straight pipe sections.

3.4.2 Outdoor jacketing

- 3.4.2.1 Jacketing shall be aluminum metal cladding. Jacketing shall be aluminum alloys 3003, 1100 or 3105 meeting ASTM B-209 with H-14 temper and a minimum 2 1/2 mil thickness polyfilm moisture barrier on the inner side. Consult jacketing manufacturer for recommended thickness. Typical thickness is 0.016”.
- 3.4.2.2 Aluminum jacketing for fittings, tees, elbows, valves, caps, etc. shall be sectional, factory contoured, or field-fabricated to fit closely around insulation.
- 3.4.2.3 Banding for jacketing shall be 0.02" thick by 1/2" wide stainless steel.

3.4.3 Underground Jacketing

- 3.4.3.1. Underground jacketing shall be vapor retarder material with chemical resistance to ground water. Products to be used are SARANEX® 560 Vapor Retarder Film and SARANEX Tape as manufactured by ITW Insulation Systems or 50 mil thick self-adhesive rubberized bituminous membrane type vapor retarder product. When SARANEX 560 Vapor Retarder Film is used, refer to Figure in Appendix B. For all other jacketing, consult jacketing manufacturer for recommended installation guidelines.

4 APPLICATION

4.1 PIPING - GENERAL

- 4.1.1 Heat tracing systems shall be installed prior to insulation installation. Refer to section 3.2.3 and Figure 4 in Appendix B.
- 4.1.2 If service temperature exceeds 300°F for anything other than brief or infrequent time periods, install an inner layer material other than TRYMER insulation recommended for higher temperature service. Install TRYMER Insulation on the outer layer. Refer to Figure 3 in Appendix B for details of a composite system.
- 4.1.3 Orient longitudinal joints between half sections of the outer insulation layer in the 3 and 9 o'clock position on the pipe. Refer to Figure 1 in Appendix B. Staggered joints are not required in this service.
- 4.1.4 Install pre-fabricated insulation fittings on elbows, tees, and valves. Insulation at fittings shall be the same thickness as on pipe sections.
- 4.1.5 Bottom insulation sections in pipe hangers and saddles shall be TRYMER 3000, 4000 or 6000 Insulation for resistance to compression on pipe diameters 4" and greater. Depending on the saddle length and span chosen for a specific job, lower density TRYMER insulation such as TRYMER 2000 XP insulation may be sufficient to be used as saddle insulation. Consult insulation manufacturer for your specific scenario. Saddles shall wrap the insulation in an arc between 120° and 180° depending upon the load.
- 4.1.6 Insulation shall be secured to the pipe with 3/4" wide fiber reinforced tape. Tape shall be applied as per Figure 2 in Appendix B.
- 4.1.7 Insulation shall be secured with fiber reinforced tape on both inner and outer layers of a double layered system if double layering is required.
- 4.1.8 All insulation shall be tightly butted and free of voids and gaps. Weather seal shall be continuous. All fasteners and bands shall be neatly aligned, and overall work must be of high-quality appearance and workmanship.
- 4.1.9 Expansion joints constructed of loose fill glass fiber insulation shall be installed in the piping insulation system where necessary. See figure 5 in Appendix B. The appropriate designer or engineer must specify the spacing of expansion joints separately for each system. Recommended expansion/contraction joint spacing is shown in table 1 in Appendix B.
- 4.1.10 A pipe coating system may be recommended to minimize the likelihood of pipe corrosion. Consult section 5.1 in Appendix A for conditions where pipe coating systems are suggested.

4.2 INDOOR PIPING

- 4.2.1 This section covers indoor areas including, but not limited to, mechanical rooms, process areas, and inhabited areas. Consult applicable codes for areas where flame and smoke requirements may apply.
- 4.2.2 Refer to section 3.4.1 for material specification on indoor protective jacketing.
- 4.2.3 Seal around protrusions, such as valve stems with a full bead of silicone sealant.

4.3 OUTDOOR PIPING

- 4.3.1 This section covers outdoor areas including, but not limited to, process areas, rooftops and roof top equipment.
- 4.3.2 TRYMER Insulation shall be protected from prolonged exposure to UV light and weather upon installation.
- 4.3.3 Refer to section 3.4.2 for material specification on outdoor protective jacketing.
- 4.3.4 Outdoor jacketing overlap shall be a minimum of 2" at butt joints and a minimum of 2" at longitudinal joints. Jacketing shall be caulked before closing and banding and positioned in an orientation to avoid water infiltration.
- 4.3.5 Straight sections of jacketing shall be neatly secured with bands and seals with a maximum spacing of 9" on center. End joints shall be secured with bands and seals centered directly over joint. Screws, staples or other fasteners may be used on systems that do not contain a vapor retarder.

4.4 UNDERGROUND PIPING

- 4.4.1 All insulation shall be tightly butted and free of voids and gaps. Vapor and water seal must be continuous. For SARANEX 560 film, consult ITW Insulation Systems guideline on the installation of SARANEX Vapor Retarder Film and SARANEX Tape.
- 4.4.2 All fasteners and bands on protective jacketing shall be neatly aligned and overall work must be of high-quality appearance and workmanship.
- 4.4.3 Trench to be constructed per detail in Figure 6 in Appendix B.
- 4.4.4 Water tight vapor seal shall be continuous around the insulated pipe. Reference section 3.4.3 for jacketing material guidelines.
- 4.4.5 Pipe shall not be submerged in water.

4.5 TANK, VESSEL, AND EQUIPMENT INSULATION

- 4.5.1 All insulation materials shall be the same as those used on the pipe associated with the tank, vessel, or equipment.
- 4.5.2 Tank and vessel head segments shall be curved or flat cut to fit in single piece or segments per ASTM C-450. Head segments shall be cut so as to eliminate voids at the head section and in a minimum number of pieces so as to eliminate through joints.
- 4.5.3 Prefabricated flat head sections shall be installed in the same number of layers and thicknesses as the vessel walls. Void areas behind the flat head shall be filled with glass fiber or mineral wool.
- 4.5.4 Curved segments shall be fabricated to fit the contour of the vessel surface in equal pieces to go around the vessel with a minimum number of through joints. Cutting in the field shall be minimized. All sections shall be tightly butted and free of voids and gaps.
- 4.5.5 Vertical vessels greater than 4 feet in diameter require an insulation support ring welded or bolted around the bottom of the tank to prevent the shell insulation from sliding down.
- 4.5.6 Secure the shell insulation with stainless steel bands on 12-inch centers.
- 4.5.7 Indoor tanks shall be covered with PVC jacketing. See section 3.4.1 for material specification on indoor protective jacketing. On outdoor equipment use aluminum jacketing. See section 3.4.2 for material specification on outdoor protective jacketing. Consult manufacturer's recommendations on jacketing thicknesses.
- 4.5.8 Caulk all joints and openings around flanges, instrument leg openings, support steel and such.

5 APPENDICES

5.1 APPENDIX A: CORROSION RESISTANT METAL COATINGS

- 5.1.1 **GENERAL NOTE** Corrosion of metal pipe, vessels, and equipment under insulation, while not typically caused by the insulation, is still a significant issue that must be considered during the design of any mechanical insulation system. The propensity for corrosion is dependent on many factors including the ambient environment and the operating temperature of the metal. The recommendations below represent the general practice in the industry but are not meant to take the place of proper system design and specification by a qualified design engineer familiar with this type of construction. We recommend that the owner consult such an engineer and have them work closely with the fabricator, the contractor, and ITW to help insure a properly designed, installed, and long-lasting insulation system free of corrosion.
- 5.1.2 **SPECIFIC RECOMMENDATIONS**
 - 5.1.2.1 **Stainless Steel** All 300 series stainless steel shall be coated with an epoxy primer at 5 mil thickness and an epoxy finish coat at 5 mil thickness if operating in a temperature range between 140°F and 300°F or if in a cycling temperature service where the service temperature is between 140° and 300°F for more than 20% of the time. Consult a coating manufacturer for appropriate coating materials and application methods based on the operating temperature range of the equipment.
 - 5.1.2.2 **Carbon Steel** All carbon steel operating at a service temperature between 32°F and 300°F or in cycling temperature service where the service temperature is between 32°F and 300°F for more than 20% of the time shall be at a minimum primer coated with an epoxy coating. Consult a coating manufacturer for appropriate coating materials and application methods for the operating temperature range of the equipment.

5.2 APPENDIX B: DETAILS

The following details are referenced in the text of this guideline by their Figure numbers. The diagrams included in this section are representative of details used within the industry. However, they are not intended to display the only accepted method of installation but to serve more as an example of commonly used and acceptable practices.

Table 1 below shows the details of expansion/contraction joints recommended while designing insulation systems with TRYMER for hot applications.

		Service Temperature (F)																			
		105	115	125	135	145	155	165	175	185	195	205	215	225	235	245	255	265	275	285	295
Ambient Temperature (F)	-10	<div style="display: flex; justify-content: space-between;"> <div style="width: 20%;">1 joint upto 17' length</div> <div style="width: 80%;">1 joint every 18' for 18' length and up</div> </div>																			
	0																				
	10																				
	20																				
	30																				
	40																				
	50																				
	60																				
	70																				
	80																				
90	1 joint every 100' for pipe lengths 100' and up	***																			
100	1 joint every 100' for pipe lengths 100' and up	***																			
110	1 joint every 100' for pipe lengths 100' and up	***																			
		***	1 joint for 20' or less	1 joint every 21' for pipe lengths 21' - 130'				1 joint every 45' for pipe lengths 130' and up													

Table 1

ABOVE AMBIENT PIPE INSTALLATION DETAIL

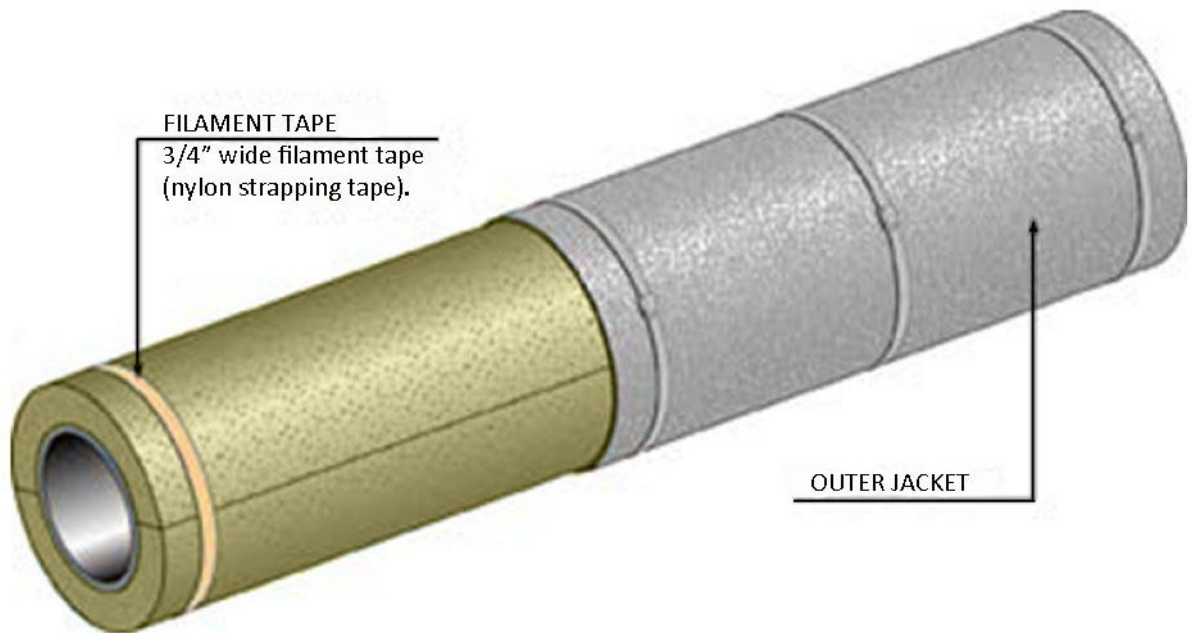

Figure 1

Detail Notes:

- Longitudinal and butt joints are not required to be staggered in above ambient service
- Refer to section 3.4 of ITW's Guideline for appropriate protective jacketing.
- Where liquid water barriers are required, use weather barrier type mastics (not pictured).
- For most systems operating at above ambient temperatures, vapor retarders should not be used (exception in cycling systems).
- In above ambient applications where water vapor intrusion is a possibility, a vapor retarder should be used.
- **In cycling systems and where vapor intrusion is a possibility a vapor retarder should be used.**

Vapor retarder shall be SARANEX® 540 vapor retarder film for service temperatures cycling to above 32°F and SARANEX 540 or 560 vapor retarder film in services cycling at and below 32°F or where a permeance of 0.02 perm or better is required. Refer to ASTM standards C-755 and C-1136 for information on selection and specification of vapor retarders. Refer to product literature and installation guidelines on SARANEX film for recommended application instructions. Elbows and fittings shall be wrapped with SARANEX 520 Vapor Retarder Tape or an approved equal. When the nominal pipe size is 6" or less, use 1" wide SARANEX 520 tape. When the nominal pipe size is between 6" and 12", use 2" wide SARANEX 520 tape. When the nominal pipe size is greater than 12", use 3" wide SARANEX 520 tape. When operating temperature cycles to ≤ 32°F or when a permeance of 0.02 perms or better is required, butt joints shall be wrapped with either two layers of SARANEX 520 Vapor Retarder Tape or a single layer of SARANEX 560 Tape. When operating temperature cycles to > 32°F, butt Joints shall be wrapped with a single layer of SARANEX 520 Tape. Vapor Retarder shall have a maximum permeance of 0.02 perm for applications at or below 32°F and a maximum permeance of 0.030 perm for applications where service temperatures cycle above 32°F. For other laminated membrane type vapor retarders, consult manufacturer's literature and installation guidelines. Vapor retarder may be factory or field applied to the outer surface of pipe insulation. For tanks, vessels, and equipment, use SARANEX 540 or 560 Vapor Retarder Film or approved equal.

PIPE INSULATION TAPING PATTERN

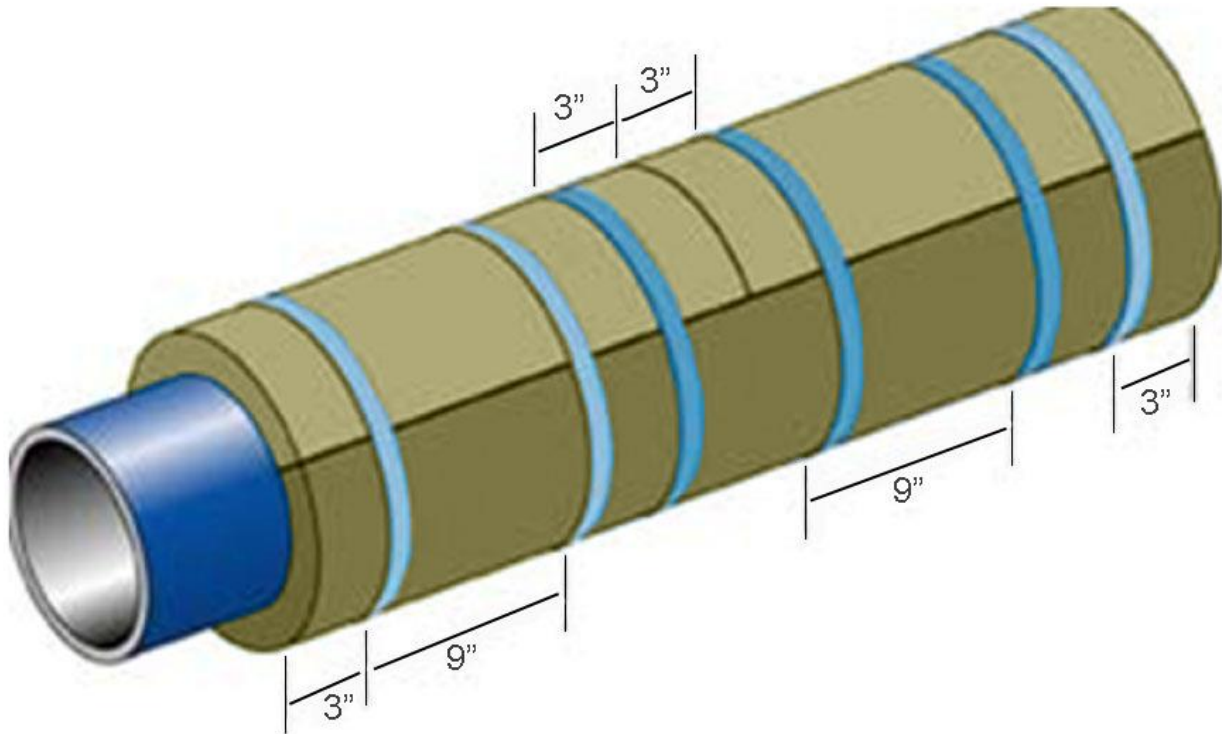

Figure 2

Detail Notes:

- Use two wraps of tape to insure adequate bond.
- Use nylon or glass filament type tape 3/4" wide.

COMPOSITE LAYER INSULATION DETAIL

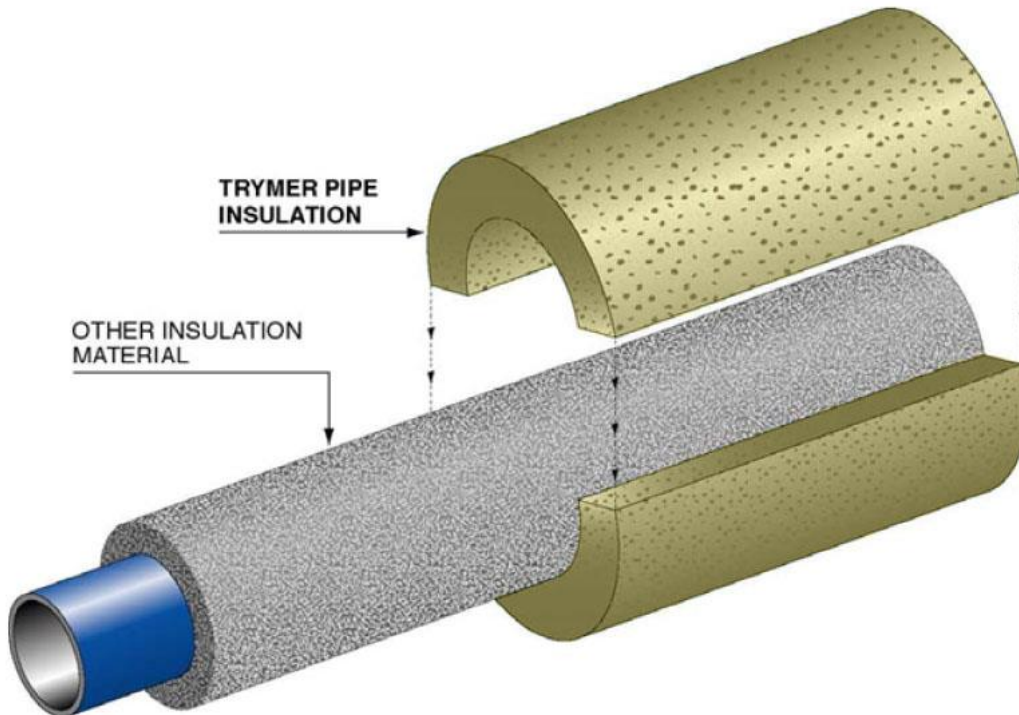

Figure 3

Detail Notes:

- Inner layer insulation must be acceptable for continuous use at highest pipe service temperature expected.
- Thickness of inner layer must be designed so that temperature at interface between inner layer and outer layer of TRYMER Insulation does not exceed 300°F.

ELECTRICAL TRACING INSULATION DETAIL

Figure 4

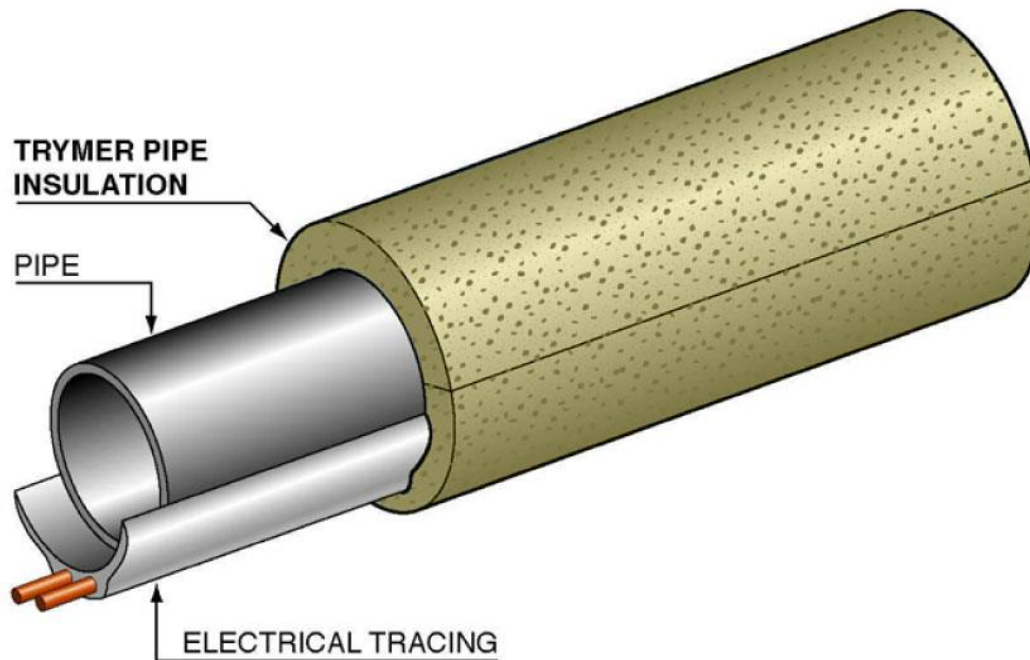

Detail Notes:

- Insulation can be fabricated with groove down center of bottom half shell or bottom half round can be oversized by 1/2” on inside diameter to allow for an annular space.
- Outer diameter of both top and bottom insulation shells are to be fabricated to the same diameter so that top and bottom sections match.
- Do not oversize the bottom half shell of insulation at pipe hangers and supports.
- When oversizing the bottom half shell, the insulation thickness of the bottom half shell shall be that specified as the “design thickness”. The insulation thickness of the upper half shell shall be 1/2” larger than the “design thickness” so that the outer diameters of the top and bottom half shells match.

EXPANSION/ CONTRACTION JOINT DETAIL

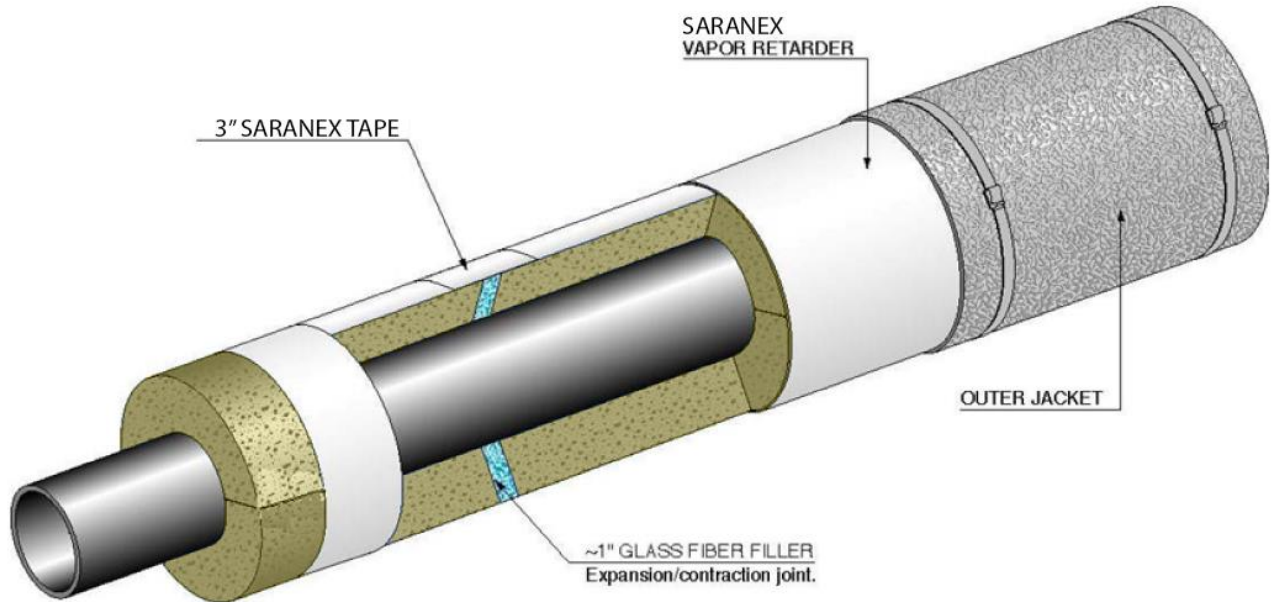

FIGURE 5

Detail Notes:

- For use in hot applications.
- Position glass fiber at insulation butt joints as shown above.
- After glass fiber in contraction joint is installed, insulation sections on either side of expansion/ contraction joint shall be held together with vapor retarder and/ or 3” butt joint tape.

UNDERGROUND TRENCH INSULATION DETAIL

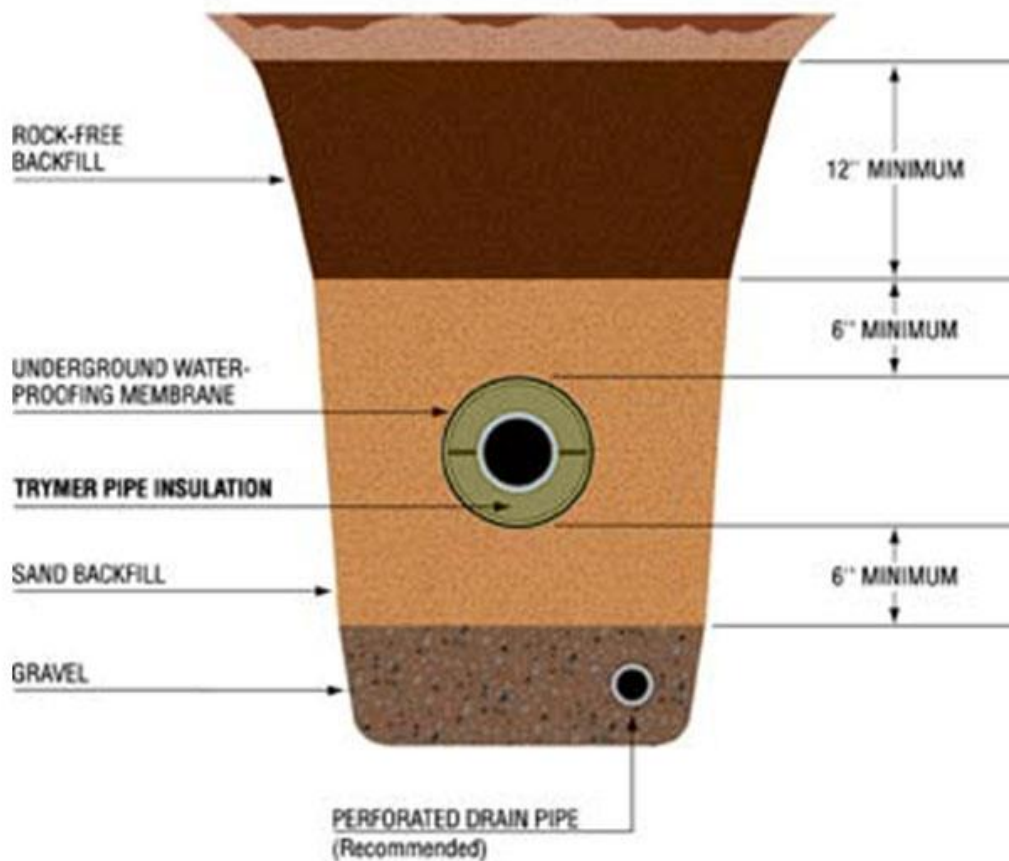

Figure 6

Detail Notes:

- Insulation shall be used in conjunction with a waterproof membrane. Protective jacketing products alone are not sufficient for immersion in groundwater. Refer to section 3.4.3 of this guideline for recommended jacketing.
- Earth fill around the pipe shall be sand without contaminants that may puncture the vapor retarder.
- Drain tile in trench bottom is recommended to minimize exposure of the insulation system to groundwater.

APPENDIX C: THICKNESS TABLES

The following tables show the insulation thickness necessary for either personal protection or to limit the heat loss to a specific maximum value (≤ 8 btu/hr-ft² of outer insulation surface) and are noted as such. The tables are specific to the use of TRYMER Insulation.

When personal protection is the design criteria, insulation thickness is typically selected so that the outer jacketing surface temperature is less than 140°F. The insulation thickness in the following tables is adequate to maintain the outer jacketing surface temperature below this value.

In each of the following tables where heat loss is the design criteria, a specific harsh scenario was assumed. This included ambient temperatures of 0°F and 70°F for the outdoor and indoor scenarios, respectively. For insulation thickness guidelines in alternative scenarios, consult your ITW Sales Representative.

These thickness recommendations are solely based on the various design conditions that are shown with each table. A number of assumptions are also made, including proper system design and installation. There may be additional factors the tables do not address that could influence the end results. These thickness tables are not meant to replace a proper system design and specification by a qualified design engineer familiar with specific ambient design parameters for a given locality. We recommend that you consult such an engineer and have them work closely with the contractor and ITW to help insure a properly designed, installed, and long-lasting insulation system. Thickness calculations are performed using the 3E Plus software program that uses heat flow algorithms based on ASTM C-680-95. The required insulation thicknesses do not include a safety factor. Actual operating conditions can vary. Consult a design engineer for an appropriate safety factor.

TRYMER Brand Insulation - Thickness Table for a Hot System Indoors

(Design Criteria = Personal Protection)

Ambient temp. = 90°F
Wind velocity = 0 mph

Outer surface = Saran or PVC ($\epsilon = 0.9$)
Geometry = horizontal pipe

Insulation Thickness In Inches Necessary to Maintain Surface Temperature < 140°F

Nom pipe size (in)	Service Temperature (°F)								
	140	160	180	200	220	240	260	280	300
0.5	1	1	1	1	1	1	1	1	1
0.75	1	1	1	1	1	1	1	1	1
1	1	1	1	1	1	1	1	1	1
1.25	1	1	1	1	1	1	1	1	1
1.5	1	1	1	1	1	1	1	1	1
2	1	1	1	1	1	1	1	1	1
2.5	1	1	1	1	1	1	1	1	1
3	1	1	1	1	1	1	1	1	1
4	1	1	1	1	1	1	1	1	1
5	1	1	1	1	1	1	1	1	1
6	1	1	1	1	1	1	1	1	1
8	1	1	1	1	1	1	1	1	1
10	1	1	1	1	1	1	1	1	1
12	1	1	1	1	1	1	1	1	1
14	1	1	1	1	1	1	1	1	1
16	1	1	1	1	1	1	1	1	1
18	1	1	1	1	1	1	1	1	1
20	1	1	1	1	1	1	1	1	1
24	1	1	1	1	1	1	1	1	1
30	1	1	1	1	1	1	1	1	1
36	1	1	1	1	1	1	1	1	1
48	1	1	1	1	1	1	1	1	1
Vertical flat Surface	1	1	1	1	1	1	1	1	1
Tank top	1	1	1	1	1	1	1	1	1
Tank bottom	1	1	1	1	1	1	1	1	1

This table is based on ASTM C 680-95 heat transfer algorithms. The suggested insulation thickness values assume proper system design and installation, do not include a safety factor, and are applicable only for the specified scenario. ITW recommends that the user consult a qualified design engineer familiar with this type of construction for proper system design and specification.

TRYMER Brand Insulation - Thickness Table for a Hot System Indoors

(Design Criteria = Heat Loss Limit)

Ambient temp. = 70°F
Wind velocity = 0 mph

Outer surface = Saran or PVC (e = 0.9)
Geometry = horizontal pipe

Insulation Thickness In Inches Necessary to Limit Heat Loss to < 8 btu/hr-ft² of Outer Insulation Surface

Nom pipe size (in)	Service Temperature (°F)										
	100	120	140	160	180	200	220	240	260	280	300
0.5	1	1	1.5	1.5	1.5	2	2	2.5	2.5	3	3
0.75	1	1	1.5	1.5	2	2	2.5	2.5	3	3	3.5
1	1	1	1.5	1.5	2	2	2.5	2.5	3	3	3.5
1.25	1	1	1.5	1.5	2	2	2.5	3	3	3.5	3.5
1.5	1	1	1.5	1.5	2	2.5	2.5	3	3	3.5	4
2	1	1	1.5	1.5	2	2.5	2.5	3	3.5	3.5	4
2.5	1	1	1.5	1.5	2	2.5	2.5	3	3.5	4	4
3	1	1	1.5	2	2	2.5	3	3.5	3.5	4	4.5
4	1	1	1.5	2	2.5	2.5	3	3.5	4	4	4.5
5	1	1	1.5	2	2.5	2.5	3	3.5	4	4.5	5
6	1	1	1.5	2	2.5	3	3.5	3.5	4	4.5	5
8	1	1	1.5	2	2.5	3	3.5	4	4.5	5	5
10	1	1.5	1.5	2	2.5	3	3.5	4	4.5	5	5.5
12	1	1.5	1.5	2	2.5	3	3.5	4	4.5	5	5.5
14	1	1.5	2	2.5	3	3	3.5	4	4.5	5	5.5
16	1	1.5	2	2.5	3	3	3.5	4	5	5.5	6
18	1	1.5	2	2.5	3	3.5	4	4.5	5	5.5	6
20	1	1.5	2	2.5	3	3.5	4	4.5	5	5.5	6
24	1	1.5	2	2.5	3	3.5	4	4.5	5	5.5	6
30	1	1.5	2	2.5	3	3.5	4	4.5	5	6	6.5
36	1	1.5	2	2.5	3	3.5	4	4.5	5.5	6	6.5
48	1	1.5	2	2.5	3	3.5	4	5	5.5	6	6.5
Vertical Flat Surface	1	1.5	2	2.5	3	3.5	4	5	5.5	6.5	7
Tank top	1	1.5	2	2.5	3	3.5	4	5	5.5	6.5	7
Tank bottom	1	1.5	2	2.5	3	3.5	4	5	5.5	6	7

This table is based on ASTM C 680-95 heat transfer algorithms. The suggested insulation thickness values assume proper system design and installation, do not include a safety factor, and are applicable only for the specified scenario. ITW recommends that the user consult a qualified design engineer familiar with this type of construction for proper system design and specification.

TRYMER Insulation - thickness Table for a Hot System Outdoors (Design Criteria = Personal Protection)

Ambient temp. = 100°F	Outer surface = Metal ($\epsilon = 0.4$)
Wind velocity = 7 mph	Geometry = horizontal pipe

Insulation Thickness In Inches Necessary to Maintain Surface Temperature < 140°F

Nom pipe size (in)	Service Temperature (°F)								
	140	160	180	200	220	240	260	280	300
0.5	0	1	1	1	1	1	1	1	1
0.75	0	1	1	1	1	1	1	1	1
1	0	1	1	1	1	1	1	1	1
1.25	0	1	1	1	1	1	1	1	1
1.5	0	1	1	1	1	1	1	1	1
2	0	1	1	1	1	1	1	1	1
2.5	0	1	1	1	1	1	1	1	1
3	0	1	1	1	1	1	1	1	1
4	0	1	1	1	1	1	1	1	1
5	0	1	1	1	1	1	1	1	1
6	0	1	1	1	1	1	1	1	1
8	0	1	1	1	1	1	1	1	1
10	0	1	1	1	1	1	1	1	1
12	0	1	1	1	1	1	1	1	1
14	0	1	1	1	1	1	1	1	1
16	0	1	1	1	1	1	1	1	1
18	0	1	1	1	1	1	1	1	1
20	0	1	1	1	1	1	1	1	1
24	0	1	1	1	1	1	1	1	1
30	0	1	1	1	1	1	1	1	1
36	0	1	1	1	1	1	1	1	1
48	0	1	1	1	1	1	1	1	1
Vertical flat surface	0	1	1	1	1	1	1	1	1
Tank top	0	1	1	1	1	1	1	1	1
Tank bottom	0	1	1	1	1	1	1	1	1

This table is based on ASTM C 680-95 heat transfer algorithms. The suggested insulation thickness values assume proper system design and installation, do not include a safety factor, and are applicable only for the specified scenario. ITW recommends that the user consult a qualified design engineer familiar with this type of construction for proper system design and specification.

TRYMER Brand Insulation - Thickness Table for a Hot System Outdoors

(Design Criteria = Heat Loss Limit)

Ambient temp. = 0°F
Wind velocity = 8 mph
Outer surface = Metal (e = 0.4)
Geometry = horizontal pipe

Insulation Thickness In Inches Necessary to Limit Heat Loss to < 8 btu/hr-ft² of Outer Insulation Surface

Nom pipe size (in)	Service Temperature (°F)										
	100	120	140	160	180	200	220	240	260	280	300
0.5	1.5	1.5	2	2	2	2.5	2.5	3	3	3.5	3.5
0.75	1.5	1.5	2	2	2.5	2.5	3	3	3.5	3.5	4
1	1.5	1.5	2	2	2.5	2.5	3	3	3.5	4	4
1.25	1.5	2	2	2.5	2.5	3	3	3.5	3.5	4	4.5
1.5	1.5	2	2	2.5	2.5	3	3	3.5	4	4	4.5
2	1.5	2	2	2.5	3	3	3.5	3.5	4	4.5	4.5
2.5	1.5	2	2	2.5	3	3	3.5	3.5	4	4.5	5
3	2	2	2.5	3	3	3.5	3.5	4	4.5	4.5	5
4	2	2	2.5	3	3	3.5	4	4	4.5	5	5
5	2	2	2.5	3	3.5	3.5	4	4.5	4.5	5	5.5
6	2	2.5	2.5	3	3.5	3.5	4	4.5	5	5.5	6
8	2	2.5	2.5	3	3.5	4	4.5	4.5	5	5.5	6
10	2	2.5	3	3	3.5	4	4.5	5	5.5	6	6.5
12	2	2.5	3	3.5	3.5	4	4.5	5	5.5	6	6.5
14	2	2.5	3	3.5	4	4	4.5	5	5.5	6	6.5
16	2	2.5	3	3.5	4	4.5	5	5.5	6	6.5	7
18	2	2.5	3	3.5	4	4.5	5	5.5	6	6.5	7
20	2	2.5	3	3.5	4	4.5	5	5.5	6	6.5	7
24	2	2.5	3	3.5	4	4.5	5	5.5	6	6.5	7
30	2	2.5	3	3.5	4	4.5	5	5.5	6.5	7	7.5
36	2	2.5	3	3.5	4	5	5.5	6	6.5	7	7.5
48	2	2.5	3.5	4	4	5	5.5	6	6.5	7	8
Vertical Flat Surface	2	2.5	3	4	4.5	5	5.5	6.5	7	7.5	8.5
Tank top	2	2.5	3.5	4	4.5	5	5.5	6.5	7	7.5	8.5
Tank bottom	2	2.5	3	3.5	4.5	5	5.5	6	7	7.5	8.5

This table is based on ASTM C 680-95 heat transfer algorithms. The suggested insulation thickness values assume proper system design and installation, do not include a safety factor, and are applicable only for the specified scenario. ITW recommends that the user consult a qualified design engineer familiar with this type of construction for proper system design and specification.